

retigo®



Blue Vision 623 i - Orange Vision 623 i

General characteristics

- VISION TOUCH - Control touch panel
- Large door handle with two positions for comfort, ease of use and safety
- Curved door glass with cool down function
- Hygienic cooking chamber with rounded inside corners
- Even baking thanks to the bi-directional fan
- Perfect illumination of the cooking chamber by means of halogen lights
- Double glass door that limits the escape of heat
- Run-off tray under the door for collecting condensed water
- Removable door seal
- WSS - water saving system prevents high water consumption in all cooking modes
- Two position door catch (safety position)
- Integrated shower for easy cleaning which does not use softened water
- SDS - service and diagnostic system- automatic evaluation of microprocessor error reports
- IPX5 protection
- Optional sets 623/623
- Wall installation possibility

Model characteristics

B 623 i

- **EASY COOKING** - Fast and simple control
- **VISION AGENT** - Virtual help-mate
- **ACTIVE CLEANING** - Automatic cleaning system
- **TOUCH&COOK** - connect a program with a picture
- Coloured touch screen display
- Hot air 30 - 300 °C
- Combination 30 - 300 °C
- Steaming 30 - 130 °C
- 4 point temperature core probe
- Curved glass - helps to cool down the outer door glass
- Delta T cooking, steaming
- Low temperature cooking
- Cook Et Hold
- Regeneration
- Banquet system
- Programming - up to 1000 programs with 20 steps
- 1 speed ventilator
- Ventilator fan timing
- Separate rack timing
- Learn function
- Automatic preheating/cooling
- Autoclima - steam saturation control
- Automatic start
- QuickView - fast program overview
- Flap valve
- ACM (Automatic Capacity Management)
- ECO logic
- Double glass doors preventing heat escape
- Turbo steam function - fast steam
- USB Plug-in
- LAN - internet communication channel

Optional

- Safety door opening in two steps
- Optional voltage 3N~/230V/50Hz

Marine specification

- o 3N~/400V/50-60Hz without N
- o 3N~/440V/50-60Hz without N

O 623 i

- Digital control display
- Hot air 30 - 300 °C
- Combination 30 - 300 °C
- Steaming 30 - 130 °C
- 99 programs with 9 steps
- Temperature core probe
- Regeneration
- Banquet system
- Curved glass - helps to cool down the outer door glass
- 1 speed ventilator
- Automatic preheating/cooling
- Automatic start
- Energy logic
- Double glass door preventing heat escape
- USB Plug-in
- LAN - internet communication channel

Optional

- Flap valve
- Safety door opening in two steps
- Optional voltage 3N~/230V/50Hz

Marine specification

- o 3N~/400V/50-60Hz without N
- o 3N~/440V/50-60Hz without N

i - injection

Optional Accessories for Retigo Vision 623 i

- ST 623 - stainless steel stand with 8 trays GN 2/3 & 8 trays GN 1/3
- ST 623 FP - stainless steel flat pack stand with 8 trays GN 2/3 & 8 trays GN 1/3
- ST 623 CS - stainless steel stand ST623 with wheels
- KN 623 - console for wall installation

Model **B 623 i - O 623 i**

drawings

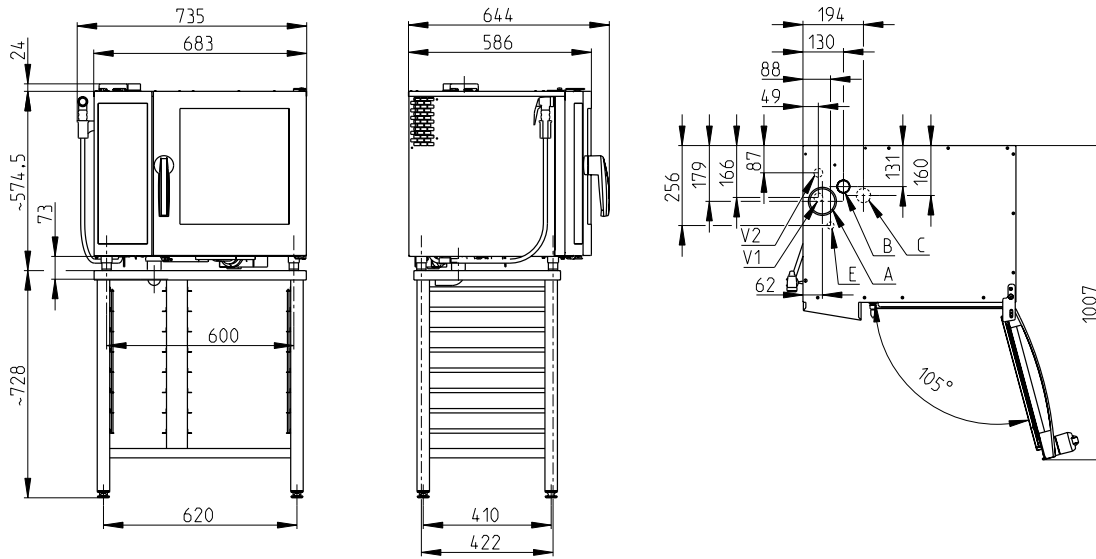

A - flap valve, B - chimney, C - drain, E - electricity, V1 - untreated water, V2 - treated water

Console for model **B 623 i - O 623 i**

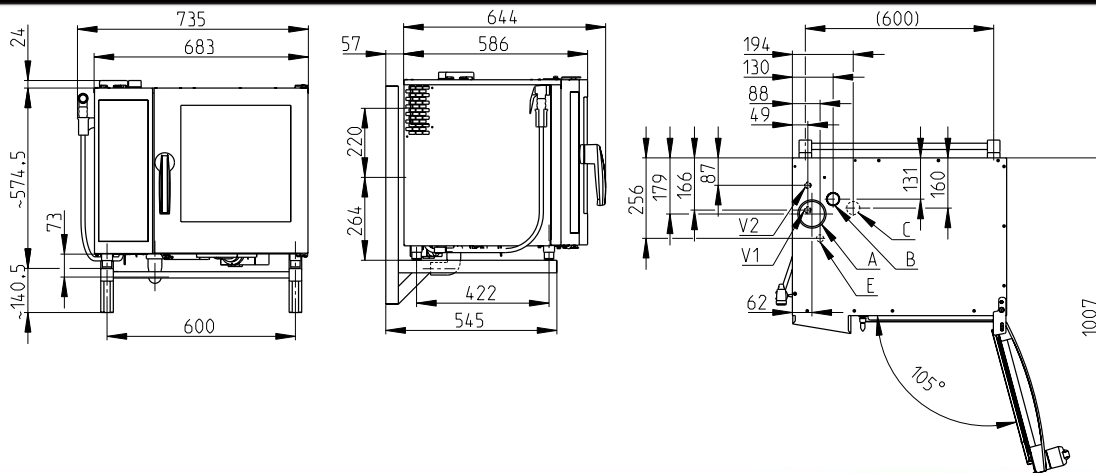

Model **623**

B 623 i; O 623 i

technical data

Energy	electricity
Steam generation	injection
Capacity	6 trays GN2/3
Capacity of meals	30 - 50
Spacing [mm]	65
Dimensions (W x H x D) [mm]	683 x 575 x 644
Weight	65 kg
Total power	4,9 kW (3,3 kW*)
Fuse protection	10 A (16 A*)
Voltage	3 N~/400 V/50 Hz
Voltage (optional)	1 N~/230 V/50 Hz
Water connection / drain (mm)	6 3/4" / 40
Temperature	30 - 300 °C
* - voltage 1 N~/230 V/50 Hz	

Size	Model	Technical specification
623	B623i	E0623IA
	O623i	E0623IZ

retigo®

RETIGO Ltd., Láň 2310, PS 43, CZ
756 64 Rožnov pod Radhoštěm
tel.: +420 571 665 511
fax: +420 571 665 554
e-mail: sale@retigo.com

TOUCH THE FUTURE

vision